

PRECISION TOOLS FOR PRECISE PERFORMANCE

Sioux Tools are known around the world for quality, durability and performance. Our extensive array of industrial power tools are engineered and built to make jobs easier, safer and more efficient. Sioux tools are designed to stand up to the demanding



specifications required by today's industrial manufacturing, assembly and finishing applications. Sioux offers a wide array of pneumatic sanders.

Let's take a look.

PNEUMATIC SANDERS - A HEADS UP ABOUT SAFETY

Any discussion of sanders requires attention to safety issues. When used improperly or under conditions of wear, sanders can cause serious injury or death. The instructions below should be followed explicitly, but cannot cover all possible situations posing danger. Good judgment is always required.

WEAR PROPER EYE PROTECTION AT ALL TIMES.



This applies both to tool users and to bystanders.



USE PROPER ATTACHMENTS.

Never mount a grinding wheel or a cutoff wheel on a sander or polisher.

INSPECT SANDING PADS FOR DAMAGE.

Damaged pads can fracture and break apart, sending debris flying into the work zone.

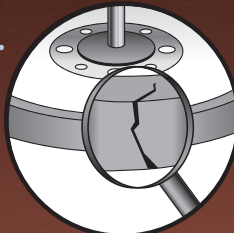

FOLLOW SPEED RATINGS CAREFULLY.

Running sanding attachments above the rated speed can cause them to fracture and break apart.

The speed rating displayed on the attachment must be greater than or equal to the RPM rating on the tool.



SECURE WORK USING FIXTURES, CLAMPS OR VISE.

Unsecured work can move violently during sanding and can pose danger.

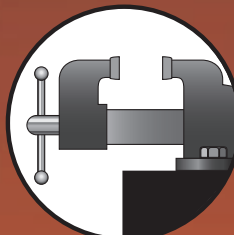

WEAR PROPER HEARING PROTECTION.

Wear proper hearing protection in order to minimize the risk of hearing loss or other impairment.



MAKE SURE THE TOOL HAS STOPPED COMPLETELY BEFORE SETTING IT ASIDE.

After the lever is released, sanders may continue to spin for a short time. Wait for the sander to stop completely.



BE CERTAIN THAT BACKING PADS AND SANDING PADS ARE PROPERLY SIZED AND IN GOOD CONDITION.

Sanding pads must be properly rated for the sander and must be the appropriate size and configuration for the backing pad.

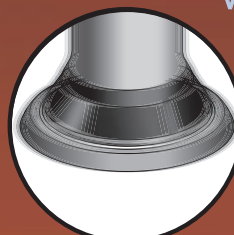

VIBRATION AND EXCESSIVE WEAR.

Prolonged exposure to vibration or excessive exposure of the sanding disk edges to the work surface can cause injury.



AVOID BREATHING PARTICULATES.

Use an approved mask.

ANATOMY OF AN ORBITAL SANDER

GRIP – Primary connection point between the user and the tool. With an ergonomic, adjustable grip, the tool feels like an extension of the body and fatigue is minimized.

LEVER – Controls the flow of pressurized air delivered to the tool.

SANDING PAD – Abrasive material that is mated to the Backing Pad to enable sanding. On one side of the Sanding Pad is the abrasive material and on the other is either an adhesive or a hook-and-loop backing.

BACKING PAD – Part of the Sander that is mated to a Sanding Pad and orbits on the work surface.

MOTOR – Transfers power from an incoming jet of air and converts it to rotational power.

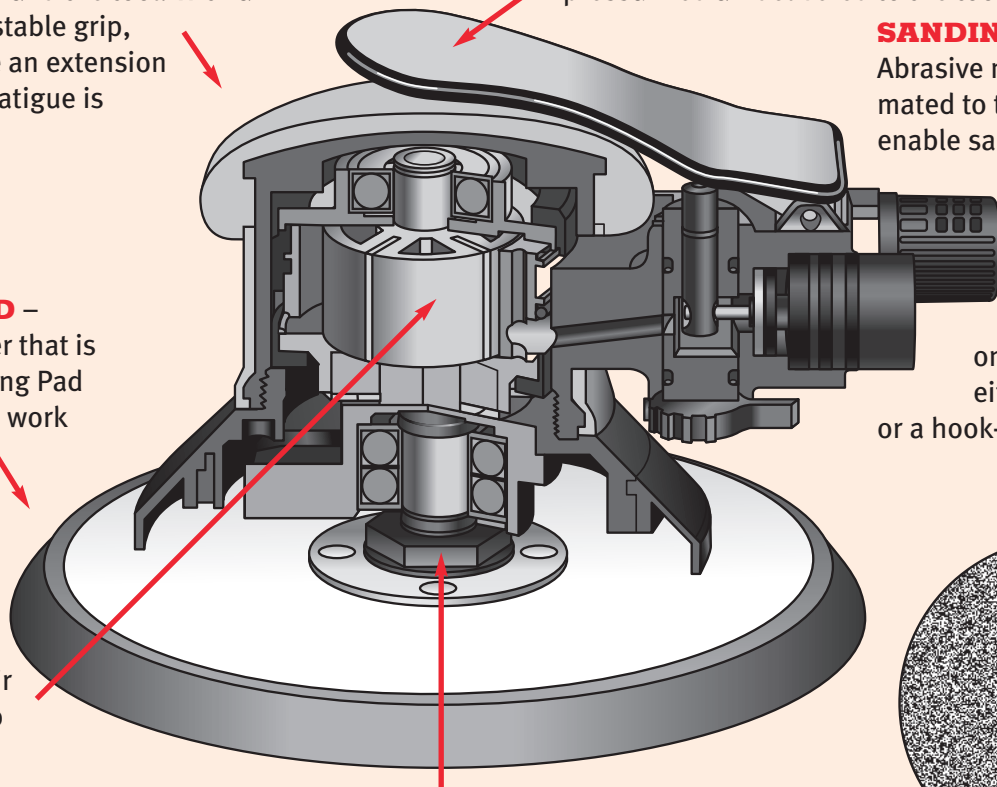

SPINDLE – Mechanical connection point for the Backing Pad or sanding accessory.

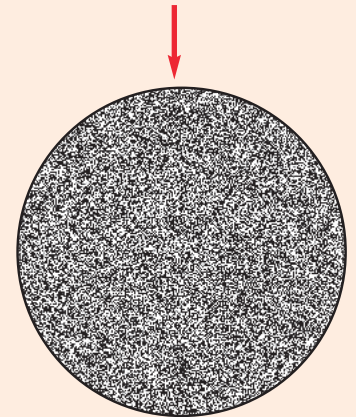

WHAT IS ORBIT?

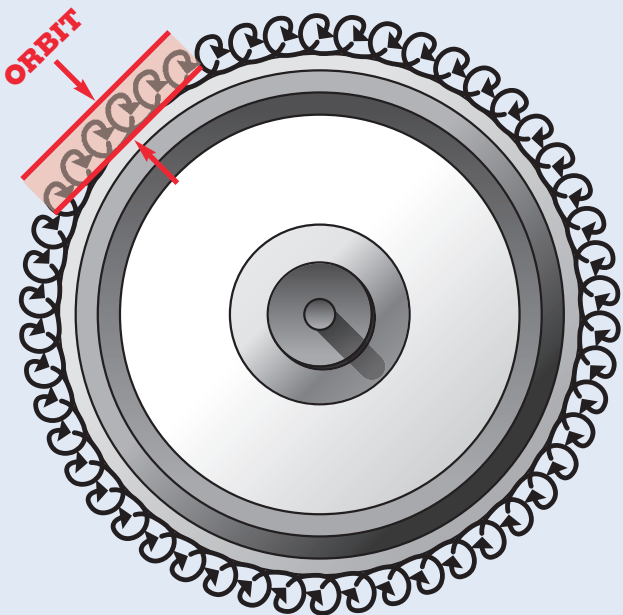

AKA **Orbit Diameter**, describes the length of “travel” of the oscillating Sanding Pad.

TYPES & SIZES OF SANDERS



Pistol Grip and Right Angle Sanders –

A family of sanders offered in a variety of motor sizes, head lengths, and RPM ranges to cover a broad array of applications.

Random
Sanders
axis of the
random
“epicycl

HOW TO "FINISH STRONG"

The following factors must be considered to ensure that the sanding job is performed optimally:

HOW MUCH MATERIAL NEEDS TO BE REMOVED?

- This will dictate the motor size, sander configuration and also provide some information of the type of grit used.
- The larger the motor size and coarser the grit, the more material it will remove.

HOW MUCH HORSEPOWER IS REQUIRED?

- For surfaces having a minimal amount of material to be removed, lower-horsepower and Random Orbital Sanders are ideal.

ARE THERE ANY HARD-TO-REACH SPOTS?

- The Jitterbug Sander's square sanding pad configuration is ideal. The corners are especially suited for accessing tough-to-reach spots.
- Pistol Grip Sanders are ideal for use on vertical surfaces.

IS THE SANDER USED IN ONE OR IN MULTIPLE APPLICATIONS?

- Pistol Grip or Right Angle Sanders are considered 'do-it-all' tools, and are often available in higher-RPM configurations to ensure capability across a wide range of surfaces.

WHICH SANDING PAD WILL WORK BEST?

- The Sanding Pad must be compatible with the Sander and also be the appropriate grit.
- Selecting a grit that is too coarse will leave swirl marks on hard surfaces and can remove too much material on more porous surfaces. This can lead to costly re-work. Conversely, too fine a grit can lead to excessive time - and number of sanding pads - required to complete the job.

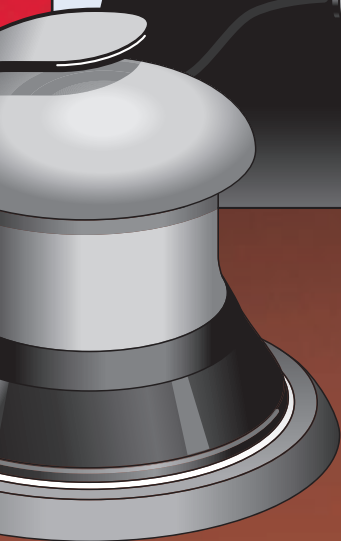

Random Orbital Sanders – Sanders that rotate along the Output Shaft and also oscillate in an "orbit" pattern.

Vertical Sanders – Sanders offered at the higher-horsepower end of the range and having the largest pad diameters.

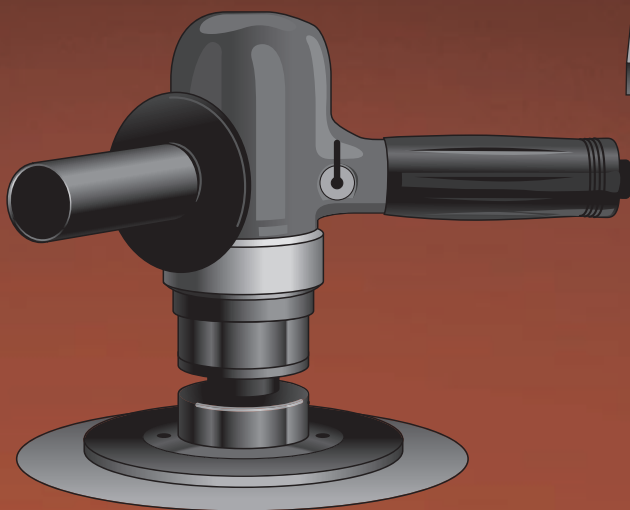

Belt Sanders – Sanders that drive a continuous loop of sandpaper.

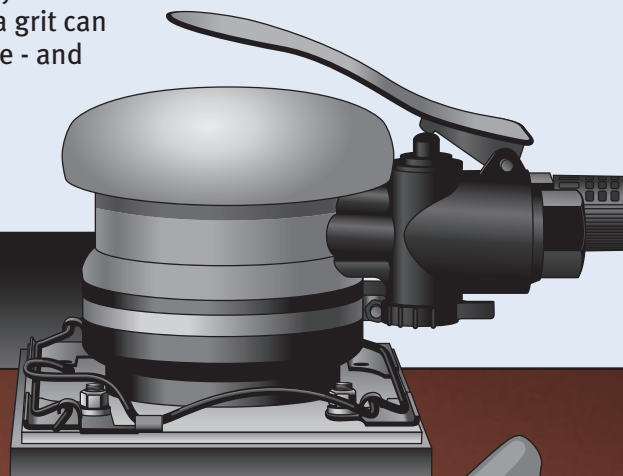

Jitterbug Sanders – Random orbital sanders that use a square-shaped Sanding Pad and are ideal for sanding hard-to-reach areas.

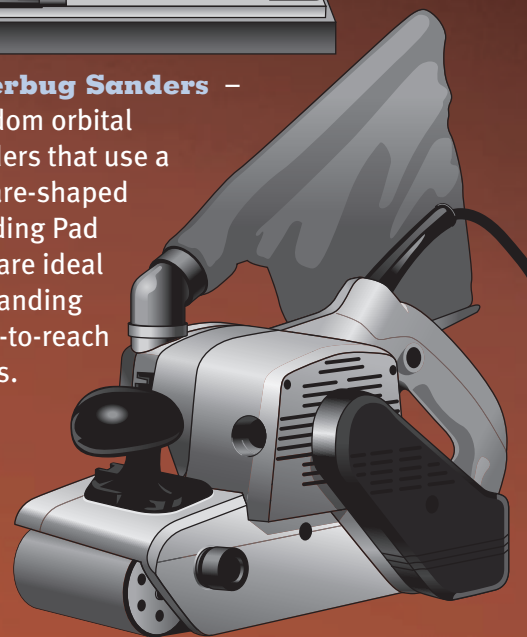

SANDING PAD CONFIGURATIONS

Sanding Pads typically attach directly to the Sander's Backing Pad by two common methods:

- **Hook and Loop:** The mechanical connection between the Sanding Disc and the Backing Pad is made by mating the Sanding Disc, having a surface covered in hooks, with the Backing Pad, having a surface covered in loops.
- **PSA:** Pressure Sensitive Adhesive Sanding Pads attach to the Backing Pad via an adhesive bond.

It is also important to select an appropriate Sanding Pad for those Sanders having an integrated vacuum. These pads have holes that allow dust to pass through them and into the vacuum's hose.

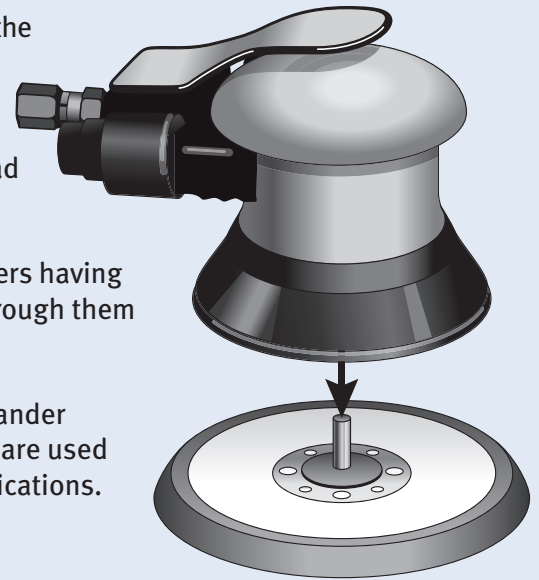

**SANDER WITH
BACKING PAD**

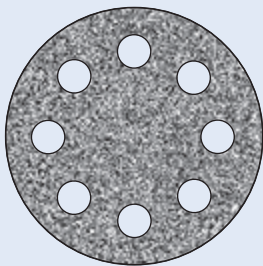

**VACUUM
SANDING PAD**

Other popular sanding attachments attach to the sander via a collet or threaded arbor. These attachments are used to access hard-to-reach spots or for special applications. Let's take a look at two popular attachments:

Poly Fiber Pads are molded, abrasive-filled bristle discs that are typically used on aluminum for deburring, blending, finishing, polishing and cleaning.

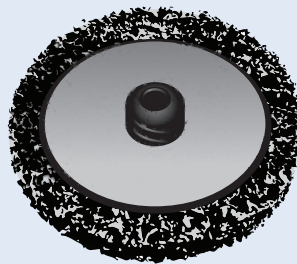

POLY FIBER PAD



BRISTLE DISC

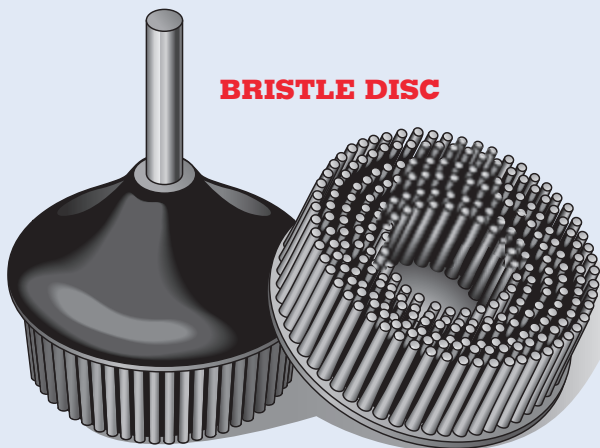

Bristle Discs are a good choice for accessing hard-to-reach places. They feature multiple layers of bristles and are used to remove rust, scale, coating and corrosion. They are also used for surface preparation, coating removal and also for removing excess molded rubber or plastic.

SIOUX offers innovative, high quality pneumatic tools for a wide array of industrial manufacturing, assembly and finishing applications.

For an in-depth look at other applications, ask your SIOUX salesperson or distributor for our companion brochures.



Snap-on Power Tools, Inc.
250 Snap-on Drive
Murphy, NC 28906

Customer Service: 866-259-7291
Email: sttechsup@siouxtools.com

See the full line of SIOUX products:
www.sioxtools.com

SIOUX Tools Available From:

SIOUX is a trademark, registered in the United States and other countries, of Snap-on Incorporated. Other marks are marks of their respective holders.

© Copyright 2017 Snap-on Incorporated. All rights reserved. Form# ZML0190 • Date: 07-17

The information contained herein is for informational purposes only and is not intended to provide instruction or to serve as a training manual. Applications for the tools described herein may vary. Additional and different steps or procedures may be required to properly complete a given task. Always wear safety glasses when operating power tools.