

PRECISION TOOLS FOR PRECISE PERFORMANCE

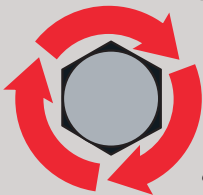

TORQUING

WHAT IS TORQUE?



Torque is rotational or *turning force*. Torque is measured in length and force: Length means distance from “center of drive” to “center of handle”; Force means “pounds”, “Newtons” etc...

The standard torque formula used to calculate torque is “Length x Force = Torque” ($L \times F = T$)

Example A: 2 ft (length of wrench) x 30 lbs (amount of force at center of handle) = 60 ft-lb of torque

Example B: 1 meter x 25 Newtons = 25 N-m (Newton-meters)

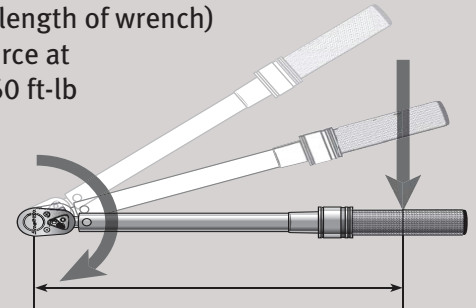

WHY IS APPLYING PROPER TORQUE IMPORTANT?

- *Safety & Performance:* Applying accurate torque is critical to assembly applications, engines and precision equipment.
- Creating a proper clamp load is the main objective when applying torque to a fastener. Engine cylinder heads, pipe couplings, wheels, all need to be “clamped” uniformly to specific torque values.
- There are three main factors that affect the correct application of torque: (1) Condition of components, (2) Accuracy of torque instrument, (3) Properly applied torque values.
- Applying torque incorrectly can lead to stripped threads, premature loosening or broken fasteners that can cause catastrophic failure. Leaking joints may cause engine or equipment failures.

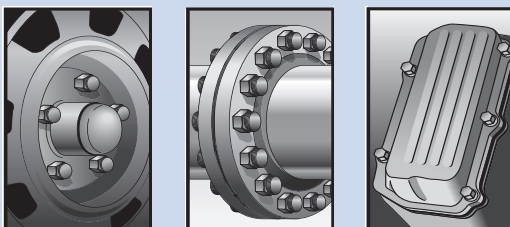

WHAT DOES TORQUE DO?

- Bolts (or threaded fasteners), are designed to create clamping force, also called “clamp load”.
- When torque is applied to a threaded fastener, it draws together the joint, (two pieces of material).
- As additional torque is applied to the fastener, the joint is compressed, creating a clamp load as the fastener begins the stretching process. It’s this fastener stretch that creates and maintains clamping force, like a stretched bungee cord maintaining tension.
- The actual amount of clamp load is determined by several factors:
 - The amount of torque applied to the fastener.
 - The material and grade of the fastener.
 - The external friction on the joint – friction under the fastener head, and friction between the threads of the fastener and material it’s connected to.

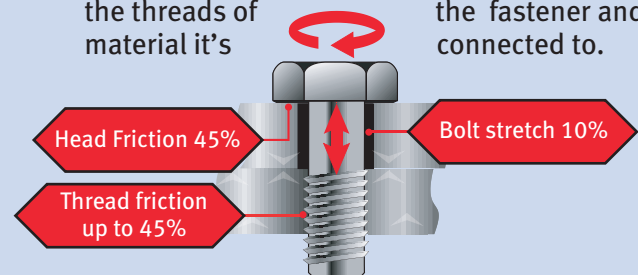

MECHANICAL TORQUING METHODS

IMPACT WRENCH

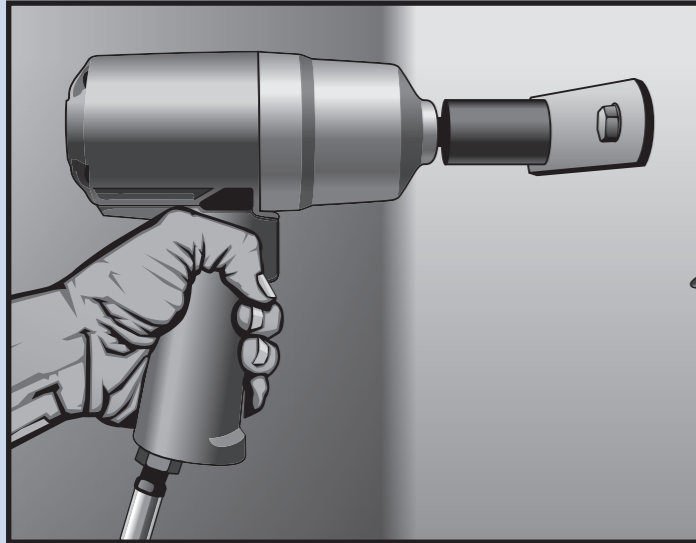

Pneumatic Impact Wrenches apply torque to bolts by a pneumatic motor. The motor drives a clutch that spins the hammer. The hammer delivers a series of blows to the anvil. Upon delivering the blow, the hammer “cams out” of engagement, spins, and repeats. The anvil drives the attached socket that torques the fastener.

STALL DRIVE SCREWDRIVERS

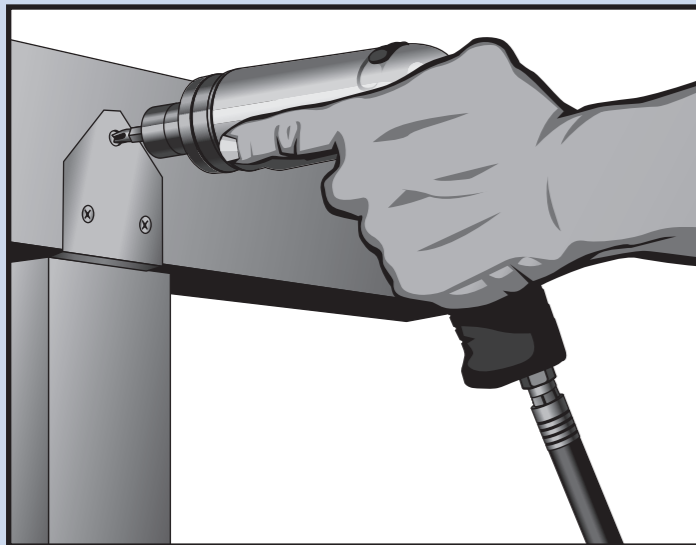

Stall Drive Screwdrivers feature a basic design where the spindle is mated directly to the motor. Final torque is adjusted by changing the air pressure.

POSITIVE CLUTCH SCREWDRIVERS

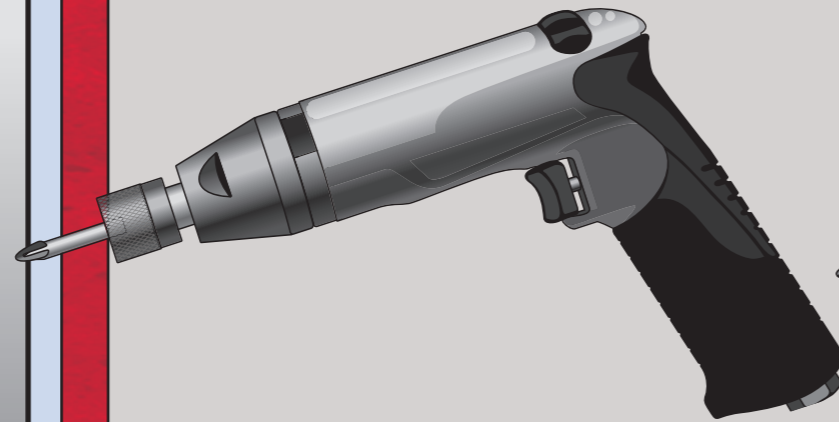

Positive Clutch Screwdrivers apply torque through a preset clutch assembly that is engaged only when the user pushes the tool toward the work surface. The clutch disengages when the motor’s maximum torque is reached, or when the operator stops pushing. The operator’s pushing force allows the user to install fasteners that require high run-down torque, such as self-tapping screws, while minimizing the risk of exceeding allowable final torque. The clutch assembly cams out when torque exceeds the desired torque level.

ADJUSTABLE CLUTCH SCREWDRIVERS

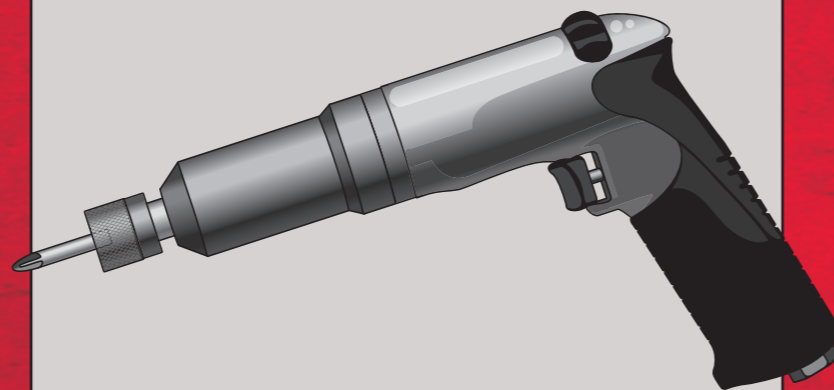

Adjustable Clutch Screwdrivers feature user adjustable torque settings. Once set, the tool will “cam out” and ratchet in place when maximum torque output is reached. This action also generates an easy-to-recognize sound, alerting the operator to reduce trigger pressure.

TORQUE CONTROL SHUTOFF SCREWDRIVERS



Torque Control Screwdrivers feature user adjustable torque settings. During operation, the screwdriver shuts off automatically when the pre-set torque level is reached. Often, these tools feature either a ‘push to start’ or “trigger start” function to improve the ease of use in the given application.

PULSE TOOLS

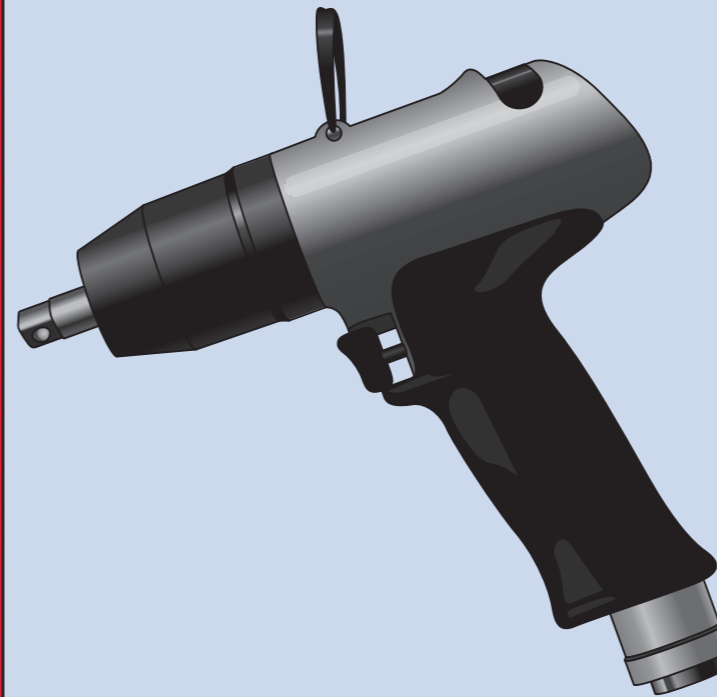

Pulse Tools apply torque via pulses of hydraulic fluid that drive the spindle, which in turn torques the fastener. Torque levels are controlled by adjustments to hydraulic pressure settings. Pulse Tools deliver high torque levels with minimal vibration.

DC NUTRUNNERS



DC power drives a motor that delivers torque to a gearbox, which, in turn, drives a spindle. DC Nutrunners drive the fastener with extreme precision and shutoff automatically upon achieving the desired output torque. Nutrunners can also control the total angle of torquing for those applications that require it.

TORQUE MULTIPLIERS

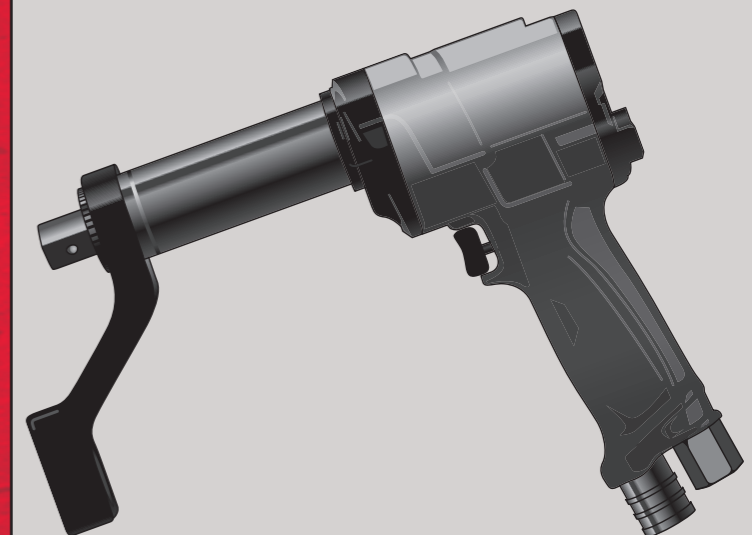

Pneumatic Torque Multipliers apply torque via a pneumatic or DC motor that drives a series of gears that, in turn, deliver torque to the output spindle. The spindle drives the attached socket that torques the fastener. Torque Multipliers are capable of extremely high levels of torque. The tool is prevented from rotating during torquing by the reaction arm. Torque output levels can be adjusted by adjusting air pressure.

TORQUE CALIBRATION

CALIBRATION CERTIFIED

It may be necessary to calibrate power tools when using them for torquing applications. Power tools can be calibrated using a variety of torque measuring devices, and the method of calibration used should ensure that the tool provides the desired output torque and operates within acceptable tolerances for the application.

When tools are calibrated, a Calibration Certification is typically provided. This document shows the date range for which the certificate is effective, and any other particulars about the tests, such as measured air pressure and expected tolerance range for the application.

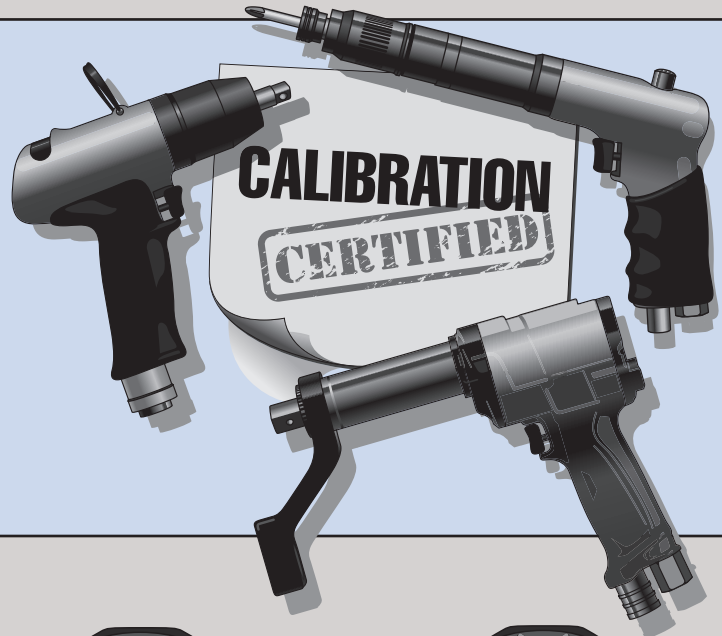

GENERAL RECOMMENDED TORQUES (FT-LB)



SAE Grade > Thread Pitch > Thread Condition >	GRADE 2				GRADE 5				GRADE 8			
	Coarse		Fine		Coarse		Fine		Coarse		Fine	
	Lube	Dry	Lube	Dry	Lube	Dry	Lube	Dry	Lube	Dry	Lube	Dry
1/4"	4.1	4.8	4.7	5.7	6.3	7.6	7.3	8.7	8.9	11	10	12
5/16"	8	10	9	11	13	16	14	17	19	22	21	24
3/8"	15	18	17	20	23	28	26	31	33	39	37	44
7/16"	24	29	27	32	37	44	41	50	52	63	58	70
1/2"	37	44	41	49	57	68	64	76	80	96	90	108
5/8"	73	87	82	99	113	135	127	153	159	191	180	216
3/4"	129	155	144	173	200	240	223	267	282	339	315	378

- Higher grade fasteners can tolerate higher torque, allowing greater clamp load.
 - Fine thread fasteners can tolerate higher torque and generate higher clamp load than coarse thread fasteners.
 - Thread condition affects the torque required to achieve the desired clamp force. Dirty and dry fasteners require more torque to achieve the same clamp force.
- Note: Always follow manufacturers specifications for torque. These are reference values and vary with fastener manufacturer and application.

SIOUX offers innovative, high quality pneumatic tools for a wide array of industrial manufacturing, assembly and finishing applications.

For an in-depth look at other applications, ask your SIOUX salesperson or distributor for our companion brochures.



Snap-on Power Tools, Inc.
250 Snap-on Drive
Murphy, NC 28906

Customer Service: 866-259-7291
Email: sttechsup@siouxtools.com

See the full line of SIOUX products:
www.siouxtools.com

SIOUX Tools Available From: